

**Data sheet**  
**for the SS-TC-Series tank**

**300**

**500**

**750**

**1000**

**1200**

**1500**

**2000**

**3000**

**5000**

**liters**

**Vertical cold accumulator with thermal  
insulation made of foamed rubber**

# SS-TC-Series tank diagram

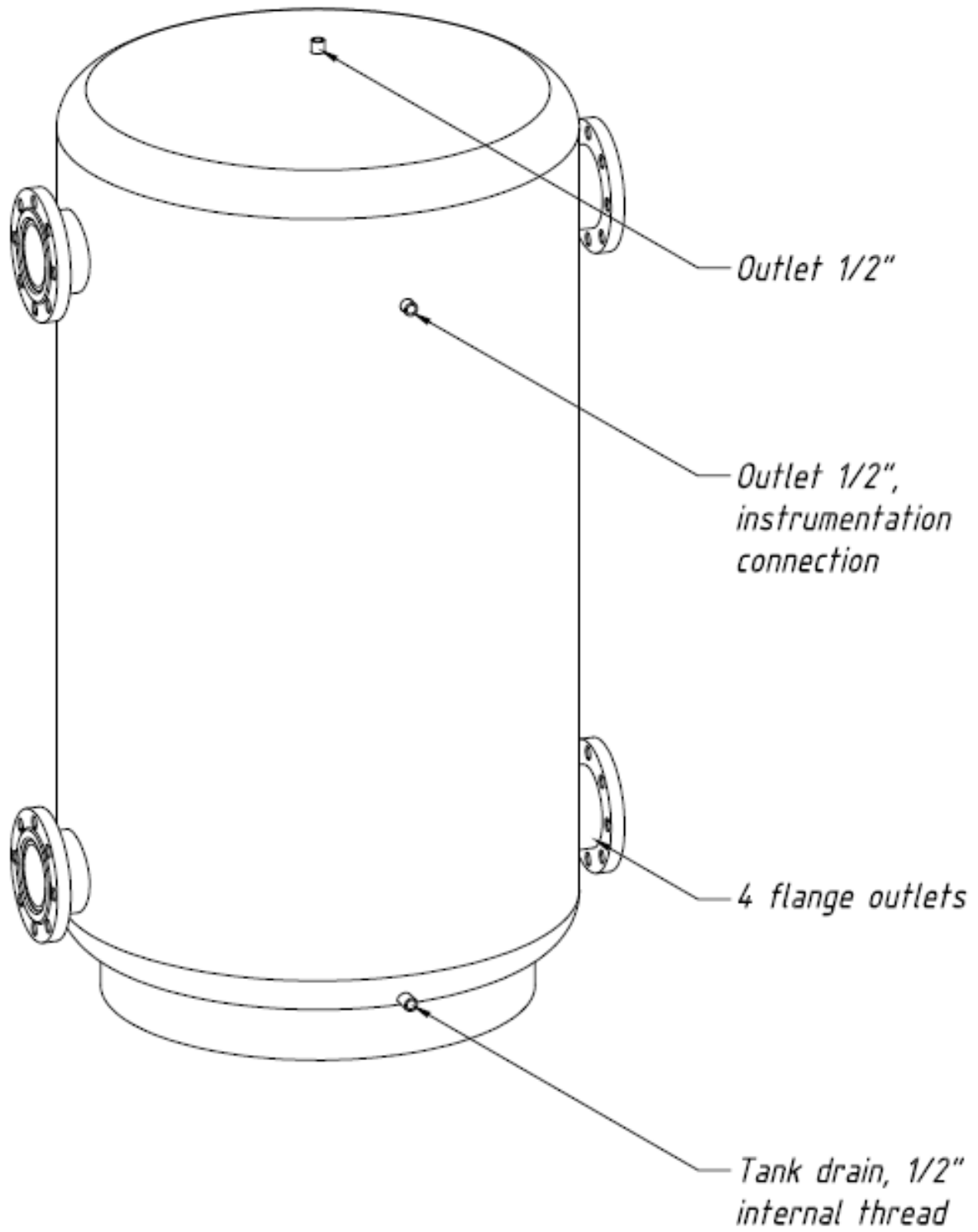

# Process functional diagram of the SS-TC-Series tank

**SMART-TANK**  
keeping the best - moving forward

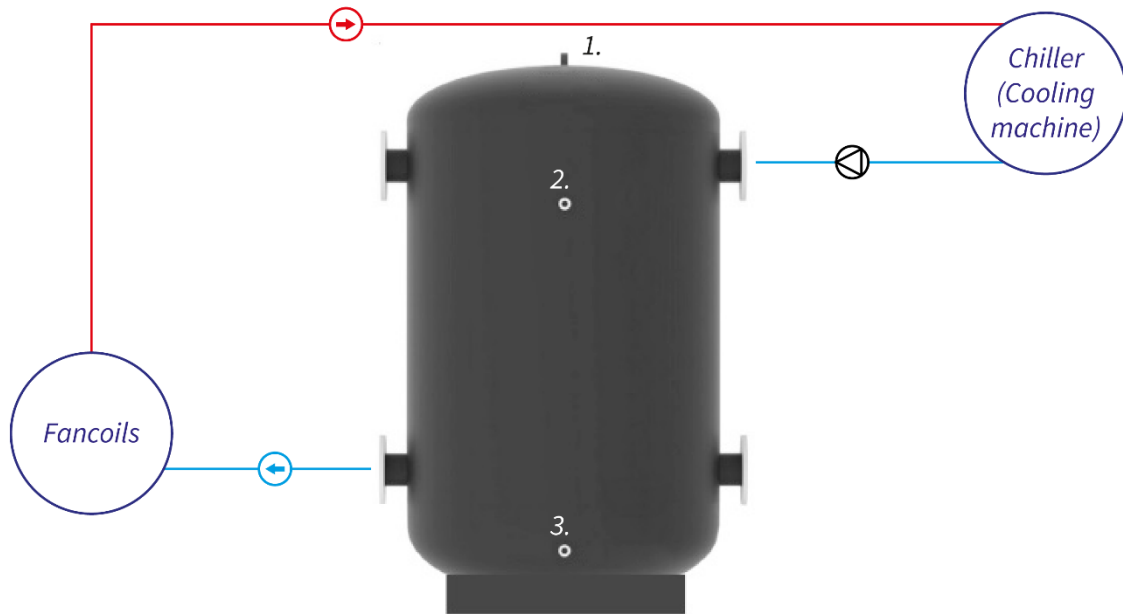

1.|2.|3. - 1/2" Inner

# Specifications

Tank Specifications	Un. of meas.	TC/SS TC 300	TC/SS TC 500	TC/SS TC 750	TC/SS TC 1000	TC/SS TC 1200	TC/SS TC 1500	TC/SS TC 2000	TC/SS TC 3000	TC/SS TC 5000
Tank volume	l	295	480	703	995	1200	1525	2030	3540/3500	4910/4900
Tank height	mm	1565	1565	1590	2165	1980	2330	2070	2315/2210	3170/3010
Tank diameter without insulation	mm	500	650	790	790	950	950	1220	1500/1600	1500/1600
Tank diameter with insulation:										
Foam rubber insulation	mm	540	690	830	830	990	990	1260	1540/1640	1540/1640
Weight	kg	65	87	103	131	174	200	246	450	615
Package dimensions: D*W*H	mm	700*800*1800	800*900*1800	930*1030*1800	930*1030*2350	1130*1050*2100	1130*1050*2500	1400*1500*2200	1800*1900*2450	1850*3200*2000
Diameter of flange connections		ДУ50	ДУ50	ДУ100	ДУ100	ДУ100	ДУ100	ДУ100	ДУ100	ДУ100
Diameter of thread connections	*	1/2 internal	1/2 internal	1/2 internal	1/2 internal	1/2 internal	1/2 internal	1/2 internal	1/2 internal	1/2 internal
Minimum operating temperature [°]	С	(-40) -10	(-40) -10	(-40) -10	(-40) -10	(-40) -10	(-40) -10	(-40) -10	(-40) -10	(-40) -10
Maximum tank temperature	С	95	95	95	95	95	95	95	95	95
Maximum tank pressure	bar	3--6	3--6	3--6	3--6	3--6	3--6	3--6	3--6	3--6
(*)-optional										

**A customized tank with operating pressure up to 10 bar may be manufactured.**

**Application:** Accumulation and accumulation of cold liquids (water, solutions of ethylene glycol, propylene glycol, alcohols) in closed systems, as well as liquids of heating systems. The standard operating range of the tank is from -10 to +95 degrees Celsius. Optionally, it is possible to perform at temperatures up to -40 degrees. It is forbidden to use in DHW systems.

**Product material:** AISI 304 stainless steel.

**Description:** The tank is intended for accumulation of cold liquids from various sources, and construction of cold supply systems. Its distinguishing feature is the presence of large-sized flange connections (from DN 50 to DN 300) (optional threaded pipes can be ordered). The SMART-TANK of the **SS-TC-Series** improves the flexibility of the cooling system, and is a hydraulic separator of the system circuits. Combines well with the following sources of cold:

- *Chiller*
- *Heat pump (in cooling mode)*
- *Industrial refrigeration systems*
- *Geo-collector*
- *Solid fuel boiler*

The presence of such a tank in the refrigeration system extends the life of the compressor units of refrigeration machines, by increasing the system's impulsivity and reducing the number of compressors on and off. In the case of a solid fuel boiler, such a container protects the boiler from emergency boiling and subsequent explosion, and also increases the efficiency of the boiler, reduces fuel consumption by 50%, and prevents the chimney from actively growing with tar.

The tank, depending on the purpose of operation, can be insulated with the following materials:

- The outer surface of the tank is covered with a 20mm black foamed rubber coating. The inner surface of the tank is not painted in accordance with the requirements for tanks operating as part of heating and cooling systems.

- When the tank is used in a heating system, the insulation of the tank can be made of 70 mm thick NOFIRE polyester material, 100% recyclable (environmentally friendly material), the material has a high coefficient of heat transfer resistance, as well as a high fire resistance class B-s2d0 in accordance with European requirements EN 13501.

At the request of the customer, the tank can be manufactured in the following modifications:

- full carbon steel + tank insulation
- completely in stainless steel AISI 304 + insulation (tank marking in this case - SS-TC).

- with any configuration of nozzles and flanges on the tank
- with different thickness of insulation at the request of the customer
- with changing the diameter and height of the tank
- with additional heat exchangers

## **1. Placement, installation, operation:**

1.1 Installation of the tank should begin with familiarization with the technical data sheet and instructions for the installation and operation of tanks, (read on (<http://smart-tank.pl/en/>))

1.2. The location of the tank must be chosen so that:

- in the event of a leak in the tank, water could go into the sewerage ladder and thus be removed from the room without consequences;

- to protect it from shock, industrial vibration, exposure to atmospheric precipitation (installed only indoors). Any impact or mechanical impact can lead to a violation of the heat-insulating material, as well as to a violation of the tightness and, as a result, failure of the tank!

When proceeding with the installation, it must be remembered that the tank must be freely accessible for connection, maintenance or dismantling.

1.3 Installation of the tank is carried out by qualified specialists and persons who have a certificate or license to perform work related to the installation of heating systems! Requires confirmation of installation in the warranty card.

1.4. - The tank must be grounded; for this, one or more plates are welded to the bottom of the tank on its supporting part for attaching to the pallet, which, in turn, can be used to connect the earth to the tank. The resistance of the ground bus should be no more than 4 ohms. Access to the ground bus is provided by the customer.

- The heating (cooling) system must be equipped with an expansion tank with a volume of 10% of the system volume.

- Replacement of the magnesium anode at least once every 6 months, if available (optional).

1.5. Acceptance of the goods in terms of quality, completeness and quantity of commodity units in the package is carried out by the Buyer within two calendar days from the date of receipt of the goods, but no later than 14 (fourteen) calendar days from the date of transfer of the goods.

1.6. It is impossible to start operating the tank without filling it with technical liquid (prepared water, antifreeze, etc.)

1.7. The tank must not be operated without a working safety valve. The condition of the safety valve must be checked every 14 days - by turning the head (knob) to the left or right so that the liquid flows from the side outlet to the outside. Then set the knob to its original position. If fluid does not flow when turning the knob, the valve is defective. When a continuous leak of liquid is observed after turning the knob and after returning to its previous position, the valve plunger is contaminated. Flush the valve several times by opening the outflow by turning the knob. To avoid uncontrolled outflow of water, it is necessary to install a hose to drain the liquid into the sewer.

The company is not responsible for the poor performance of the safety valve caused by incorrect installation of the valve and errors in the system, such as the absence of a pressure reducing valve in the cold water supply system.

1.8. Do not block the dripping of liquid from the safety valve - do not plug the opening of the safety valve. If liquid leaks out of the valve all the time, this means that the pressure in the system is too high or the safety valve is faulty. The outlet of the drain valve must point downwards. It is recommended to put a funnel under the valve to drain the liquid. It is possible to install a drain hose and direct it to the sewer to remove the liquid that occurs when the safety valve is opened. The hose must withstand a temperature of +95 degrees Celsius with an inner diameter of 9 mm, a maximum length of 1.2 m, a flat outlet with a downward slope (min. 3%), in a room where the temperature does not fall below 0 degrees Celsius. The hose must be protected from mechanical damage and its exit must be visible (to check the operation of the valve)

1.8.1 The tank must be equipped with an expansion tank with a volume of 10% of the volume of the entire system. It is forbidden to install shut-off valves (taps, non-return valves, etc.) between the expansion tank and the cold accumulator.

1.9. The tank must not be placed in the immediate vicinity of an open flame, or come into contact with the insulation of the boiler itself; when installing the heating system with a tank, the installer must ensure compliance with fire safety standards during operation!

1.10. All maintenance and installation work must be carried out in accordance with current safety regulations.

## **2. Tank selection:**

2.1 The choice of the tank is carried out individually according to the parameters of the heating system, or according to the project documentation.

2.2 The manufacturer reserves the right to make technical changes in accordance with the design documentation.

### **3. Warranty:**

3.1 The manufacturer guarantees the compliance of SMART-TANK **SS-TC-Series** storage tanks with safety requirements, provided that the consumer complies with the rules of transportation, storage, installation and operation. Warranty period - 2 years from the date of sale. The warranty period for the exterior paintwork is 6 months, subject to the rules of storage and transportation.

The product is to be registered by mailing the required information to the manufacturer's address [service.heatex@gmail.com](mailto:service.heatex@gmail.com), the List of required documents is provided in Installation and Operating Manual in case the product is not registered, the warranty period is 1(one) year from the date of sale.

3.2 The procedure for fulfilling warranty obligations. If the claims under the warranty are justified, the SMART-TANK service department decides how the identified deficiencies can be eliminated - by repairing or replacing the faulty device. The warranty period specified in the warranty card does not change. If a defective device is replaced with a new one, the warranty period is not extended, and a note about the replacement is made in the warranty card.

3.3 The warranty does not cover defects that have arisen through the fault of the consumer as a result of violation of the installation and operation rules, the requirements of the technical passport, as well as in the presence of mechanical damage.

3.4. For defects discovered during the warranty period, please contact the manufacturer/importer. Free repair of faults caused by the fault of the manufacturer will be carried out within the period specified in the current legislation, from the date of confirmation by the manufacturer/importer that the case is covered by the warranty.

**WARNING** - Do not dismantle the tank in the event of a complaint before obtaining permission from the manufacturer.

3.5. To submit a complaint to the importer/seller's service center, the following data must be provided: invoice number and product serial number (located on the information sticker), date of purchase, description of the fault, exact installation address and contact telephone number.

3.6. The condition for the warranty repair of the tank is the provision by the user of the sales receipt, invoice and warranty card - correctly filled out in full, marked by the seller and the



installer, not containing any corrections. The warranty card must be kept during the entire period of operation of the equipment.

3.7. It is forbidden to install a tank without a working safety valve. Proof of purchase for the relevant safety valve and safety valve warranty card are required to qualify for the warranty.

3.8. Installation and commissioning of the tank, which is the subject of the guarantee, must be done by a qualified specialist in accordance with the rules established by law, as well as the instructions for installation and operation (read on <http://smart-tank.pl/en/>)

3.9. Protect the tank from direct sunlight.

3.10. The tank must be installed in areas not affected by the weather (rain, snow, etc.)

3.11. To connect the tank, do not use plastic pipes that are not suitable for operation at a temperature of 100 degrees Celsius and a pressure of 1.0 MPa.

3.12. The tank should be installed in such a way as to provide free access to it for maintenance.

3.13. The manufacturer is not responsible for possible inconveniences or costs associated with structural changes to the building/rooms necessary due to the conditions of the installation site (for example, narrow doors or corridors) - the request for covering costs will be rejected by the manufacturer. If the installation of the water heater is to be carried out in an unusual location (e.g. in an attic, rooms with water sensitive floors, warehouses, etc.) it is necessary to protect the room from possible ingress of water and consider installing devices designed to collect and drain this water in order to avoid damage.

3.14. All mechanical damage to the tank will void the warranty.

3.15. The warranty does not apply if:

- the heating/cooling system using a tank was not filled with a solution of distilled water or a specially prepared solution for filling heating/cooling systems with an appropriate quality certificate (for tanks intended for heating/cooling systems).

- the heating / cooling system was not grounded (this is necessary to prevent the influence of parasitic (stray) currents on the metal and, as a result, the occurrence and acceleration of corrosion)

- in case of using the tank in heating systems with the presence of air in the network (for tanks intended for heating / cooling systems).

- if the tank has been used in a heating/cooling system not equipped with an appropriate safety group to relieve excess pressure.

- in case of installation of shut-off valves between the safety valve and the cold accumulator.

- in cases of installation of shut-off valves between the expansion tank and the cold accumulator.
- in case of using the tank in aggressive environments.
- in case of poor quality installation.
- in the absence of an expansion tank for a closed system, the required volume (10% of the system volume).
- damage caused by incorrect transportation;
- intentional damage or damage resulting from negligence;
- mechanical damage or damage resulting from the actions of atmospheric conditions (for example, frost) and actions resulting from the excess of the permissible operating pressure specified in the technical passport;
  - accidents caused by the installation or operation of defective or damaged safety valves;
  - damage resulting from misuse;
  - damage resulting from non-compliance with the rules contained in the technical passport and the Instructions for the installation and operation of tanks (read on <http://smart-tank.pl/en/>)
  - damage caused by fire, flood, lightning strike, power surges or other events;
  - accidents resulting from the use of non-original spare parts, such as a heating element block, magnesium anode, titanium anode, thermostat, thermometer, gaskets, etc.;
  - cases of electrochemical corrosion;
  - damage resulting from the lack of replacement of the magnesium anode within the time specified in the technical passport (if it is present in the tank design);

3.16. The tank repair method is determined by the manufacturer.

3.17. The free repair does not include: tank adjustments, replacement of the magnesium anode, replacement of seals or other parts that naturally wear out during operation.

3.18. These terms of the manufacturer's warranty are the only ones. No other warranties will be accepted unless expressly requested to do so in writing by the manufacturer.

3.19. For issues not regulated by these terms and conditions, the norms of the Civil Code apply.

#### **4. Storage conditions:**

To carry out storage of goods until commissioning in a dry, heated room at a temperature not lower than 20 ° C and relative humidity not more than 65%.

## Standard product package:

1. Tank – 1 pc.
2. Thermal insulation rubber (non-removable) or polyester (removable) – 1 pc.
3. Top decorative cover with insulation (plastic up to 1000 l, fabric 1200 l and more) – 1 pc.

(only for polyester insulation)

4. Passport for the product – 1 pc.

Sale date \_\_\_\_\_

Signature of Seller

Name and address of the trading organization

Seal.

Name and address of the mounting organization

Seal.

## Technical Department contact phones:

*Manufacturer:*

HEATEX Sp. z o.o

*Address:*

Poland 64-610 Rogoźno ul. Fabryczna 7 Województwo Wielkopolskie

*Website:* <http://smart-tank.pl/en/>

*Please, send your questions to:* [service.heatex@gmail.com](mailto:service.heatex@gmail.com)

*For buyers from the Republic of Poland, EU, CIS countries, and non-CIS countries:*

+48 668-769-708 (Poland, English, Russian speaking)